

NiCo



espagnolette

The Nico Espagnolette is a simple way to provide secure multi-point locking for windows.

for easy to fit window security

BBA approved, the Espagnolette is strong and reliable, offering proven long-life performance.



For maximum versatility, the Espagnolette is complemented by a selection of high pressure die cast zinc keeps designed to operate with all the major PVC-u profiles. Eccentric mushroom cams allow weatherseal adjustment of +/- 1mm.

A choice of yellow passivated finish or Supercoat 500 silver finish (tested to 480 hours salt spray) is available.



ABOVE: Nico Supercoat 500 is a special corrosion resistant coating. Test Results indicate that finished products have achieved grade 5 (exceptionally high resistance to corrosion) as defined in BS EN 1670:2007, making them suitable for environments subject to industrial or coastal pollution plant.

UK manufacture

Strong and reliable

Eurogroove application

Weatherseal pressure adjustment

Yellow passivated or Supercoat 500 silver corrosion resistant finish

BBA approved

Technical Data

Fitting Instructions

Mark the desired centre for the handle mechanism, machine a slot in the centre of the Eurogroove 12mm (10.5mm min) x 90mm long.

Drill a 12mm hole on the above centre line, 20mm or 22mm back from the front face of the Espagnolette. Also drill two 10mm holes 21.5mm either side of the centre hole. (Note: these hole sizes may vary)

Secure the Espagnolette in the sash ensuring that the handle driving mechanism is aligned with the handle mounting holes.

Set the Espagnolette in an unlocked position and locate the keeps in the frame to clear the locking cams.

Check that the locking cams are fully engaged with the keeps when the Espagnolette is locked.

Secure keeps to frame and adjust eccentric cams if necessary.

The Nico Espagnolette comes in a range of sizes, from 170mm up to 1150mm, with one to three cams and two to six fixing holes according to length.

For the two longest sizes, an additional central cam provides compression on larger sashes.

The Espagnolette is available with lockcase backsets of 20mm or 22mm, a 7mm

square spindle drive and operating handle fixing holes at 43mm centres.

The eccentrically adjustable cams, which are either 7.8mm or 9mm according to customer requirements, can be adjusted by +/-1mm for weatherseal compression.

A range of profile related keeps is available.

All Nico Espagnolettes are tested over a 30,000 duty cycle and BBA approved.

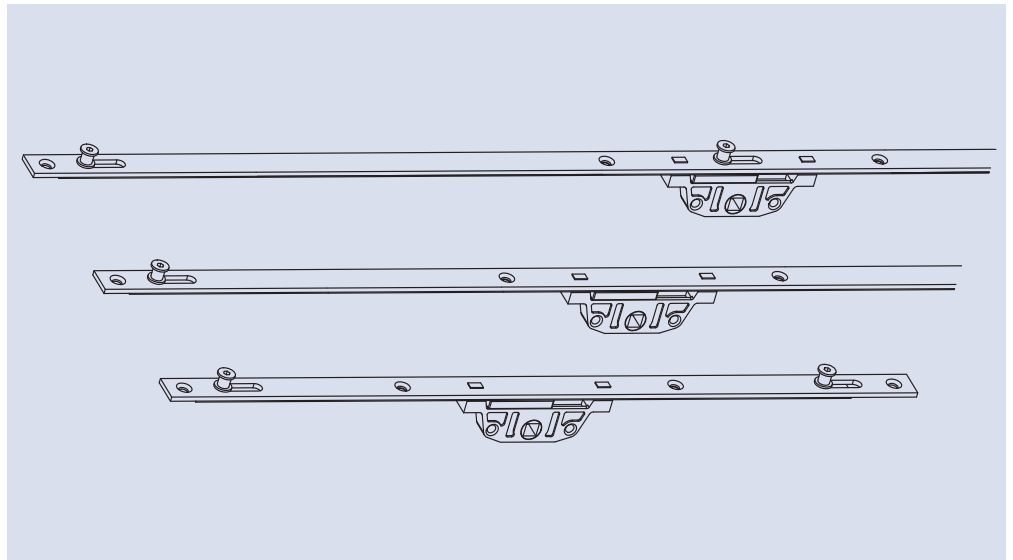

Espagnolette

PART NUMBERS: Part number shown are for Supercoat 500 finish. For Yellow Passivate finish remove the S5 from the Part Number.

20mm Backset Espagnolettes				
Description	Product Order No.(7.8mm)	Product Order No.(9mm)	Number Of Cams	Box Quantity
170mm Espagnolette bolt	98220S5	99220S5	1	20
280mm Espagnolette bolt	98320S5	99320S5	2	20
350mm Espagnolette bolt	98420S5	99420S5	2	20
550mm Espagnolette bolt	98620S5	99620S5	2	20
750mm Espagnolette bolt	98820S5	99820S5	2	20
950mm Espagnolette bolt	981020S5	991020S5	3	20
1150mm Espagnolette bolt	981220S5	991220S5	3	20

22mm Backset Espagnolettes				
Description	Product Order No.(7.8mm)	Product Order No.(9mm)	Number Of Cams	Box Quantity
170mm Espagnolette bolt	98222S5	99222S5	1	20
280mm Espagnolette bolt	98322S5	99322S5	2	20
350mm Espagnolette bolt	98422S5	99422S5	2	20
550mm Espagnolette bolt	98622S5	99622S5	2	20
750mm Espagnolette bolt	98822S5	99822S5	2	20
950mm Espagnolette bolt	981022S5	991022S5	3	20
1150mm Espagnolette bolt	981222S5	991222S5	3	20



ISO 9001 Cert No: Q 09355

Nico Manufacturing Ltd

Oxford Road, Clacton-on-Sea
Essex CO15 3TJ, England.

Tel: 01255 422333

Fax: 01255 432909

E-mail: sales@nico.co.uk

Web: www.nico.co.uk