

NiCo

MULTI LOCK

multilock locking system



for high performance window security

The Nico MultiLock is a high performance Security Locking System that is exceptionally strong and very easy to fit.

The innovative, patented twin cam design will easily achieve the BS7950 Security Standard on most pvc-U and aluminium window profiles.

A quality build and robust profile-specific keeps combine to ensure a long reliable life and light, smooth closing action. Plus, the attractive Supercoat 500 silver finish provides excellent corrosion protection.



ABOVE: Robust profile specific keeps with four fixing holes provide extra strength and security.



RIGHT: Nico Supercoat 500 is a special corrosion resistant coating. Test Results indicate that finished products have achieved grade 5 (exceptionally high resistance to corrosion) as defined in BS EN 1670:2007, making them suitable for environments subject to industrial or coastal pollution plant.

UK manufacture

Simple, secure and cost-effective

Multi-point double cam locking

Supercoat 500 silver corrosion resistant finish

10 year guarantee

Meets BS7950 security standard

Patented design

BBA approved



Technical Data

Fitting Instructions

Select a MultiLock of an appropriate length and backset.

Mark the desired centre for the handle mechanism, machine a slot in the centre of the Eurogroove 12mm (10.5mm min) x 90mm long.

Drill a 12mm hole on the above centre line, 20mm or 22mm back from the front face of the MultiLock. Also drill two 10mm holes 21.5mm either side of the centre hole. (Note: these hole sizes may vary).

Secure the MultiLock in the sash ensuring that the handle driving mechanism is aligned with the handle mounting holes.

Set the Multilock in an unlocked position and locate the keeps in the frame to clear the locking cams.

Check that the locking cams are fully engaged with the keeps when the Multilock is locked.

Secure keeps to frame and adjust eccentric cams if necessary.

The MultiLock is easy to fit and has adjustable seal compression. For fabricator convenience, it uses the same preparation as Nico Espagnolettes and Shootbolts, with common keeps across the complete Locking System range. The MultiLock is tested to loads of more 5000N and has also completed endurance testing of over 30,000 cycles.

Eccentric 7.8mm or 9mm mushroom cams allow weatherseal pressure adjustment to +/-1mm and heavy gauge materials and fixing points protect against attack.

A version with offset gearbox is also available for lower handle positions to meet the requirements of 'Design for Life'.

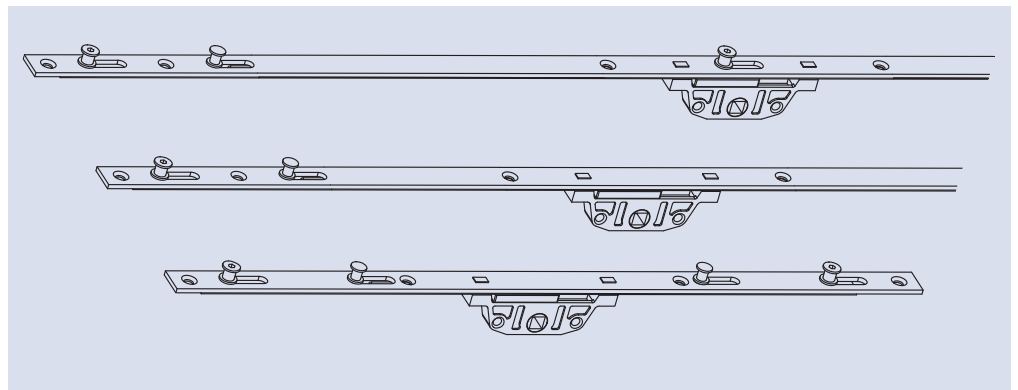

How it Works

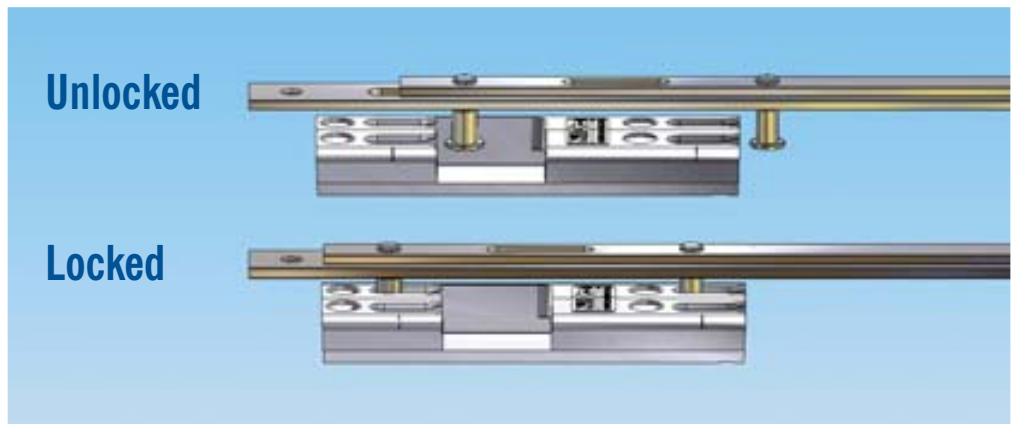

MultiLock

20mm Multilock					
Description	Backset	Part Number 7.8 Cams	Part Number 9.0 Cams	Number Of Cams	Box Quantity
270mm MultiLock	20mm	918320S5	919320S5	3	20
410mm MultiLock	20mm	918420S5	919420S5	4	20
550mm MultiLock	20mm	918620S5	919620S5	4	20
750mm MultiLock	20mm	918820S5	919820S5	5	20
950mm MultiLock	20mm	9181020S5	9191020S5	5	20
1150mm Multilock	20mm	9181220S5	9191220S5	5	20
22mm Multilock					
Description	Backset	Part Number 7.8 Cams	Part Number 9.0 Cams	Number Of Cams	Box Quantity
270mm MultiLock	22mm	918322S5	919322S5	3	20
410mm MultiLock	22mm	918422S5	919422S5	4	20
550mm MultiLock	22mm	918622S5	919622S5	4	20
750mm MultiLock	22mm	918822S5	919822S5	5	20
950mm MultiLock	22mm	9181022S5	9191022S5	5	20
1150mm MultiLock	22mm	9181222S5	9191222S5	5	20

Secured by Design



ISO 9001 Cert No: Q 09355

Nico Manufacturing Ltd

Oxford Road, Clacton-on-Sea
Essex CO15 3TJ, England.

Tel: 01255 422333

Fax: 01255 432909

E-mail: sales@nico.co.uk

Web: www.nico.co.uk