

# NiCo

www.nico.co.uk



## shootbolt locking systems

### for high performance window security

The Nico range of high performance Locking Systems includes a choice of two croppable security Shootbolts.

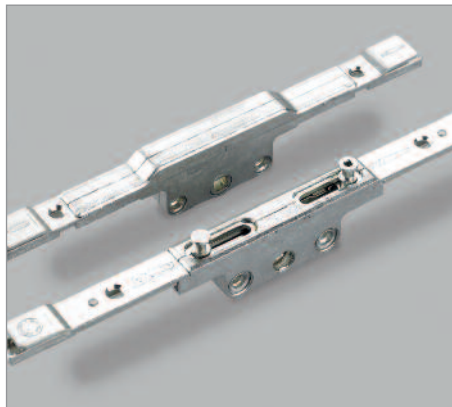

*ABOVE: Nico Shootbolts showing different gearboxes. Top. Mark One Shootbolt. Below. Mark Two Shootbolt with twin cam system.*

Successfully tested as a critical component within PAS024:2016, the Mark Two Centre Cam Shootbolt and Mark One Shootbolt are designed for strength and reliability.

Built to the most exacting quality standards, Nico Shootbolts provide an effective, secure locking system and a smooth closing action.

Both Shootbolts have shoots and mushroom cams in the corners. The Mark Two Shootbolt has additional cams in the centre and Mark One has additional mushroom cams on longer extensions.



*ABOVE: Nico Supercoat 500 is a special corrosion resistant coating. Test Results indicate that finished products have achieved grade 5 (exceptionally high resistance to corrosion) as defined in BS EN 1670:2007, making them suitable for coastal or industrial environments.*

**Secured by Design**



**Police Preferred Specification**

SBD Approved Product

UK manufacture

Choice of two designs

Excellent security and reliability

Meets PAS024:2016 as critical component

Simple to install

Supercoat 500 silver corrosion resistant finish

**For sales, call 01255 422333 or email [sales@nico.co.uk](mailto:sales@nico.co.uk)**

## Fitting Instructions

Fit the gearbox to a prepared sash (12 x 110mm slot). Refer to the handle symbol on the gearbox faceplate to determine the correct handle locked position direction.

Mark extensions for cropping using the index marks on the gearbox faceplate.

Crop the extensions to length.

Fit the teeth of the extension into the gearbox coupler (under the faceplate), slide the cover under the gearbox faceplate and insert screws.

Fit the keeps using the index marks on the sides of the keeps as a guide to the cams locked position.

Full illustrated fitting instructions are available from our customer service department.

# shootbolt locking systems

## Technical Data

Nico Shootbolts have been tested to exceed the requirements of PAS024:2016 as a critical component and offer class-leading strength and resistance to force.

Mark One and Mark Two Shootbolts have been endurance tested to 30,000 cycles in the Nico Test Centre to ensure a long, trouble-free life.

Fast and easy to fit with Eurogroove application, Nico Shootbolts feature a 20mm or 22mm backset and cams at 7.8 or 9mm.

Compression can also be adjusted by the eccentric mushroom cams to +/- 1mm.

### Mark One Shootbolt

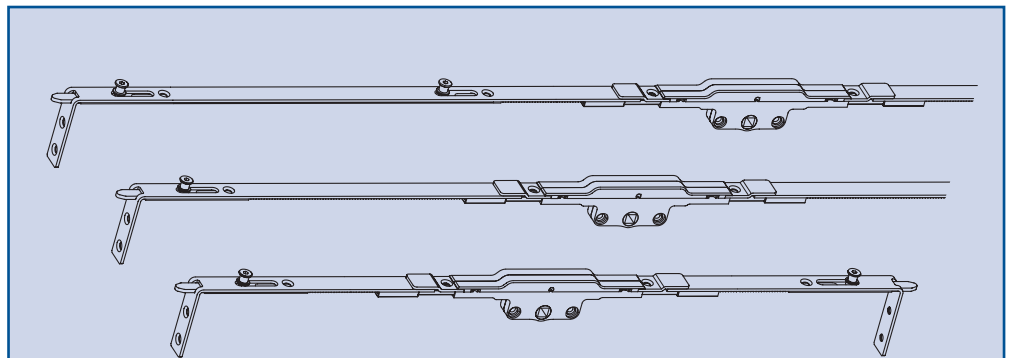

#### Mark One Shootbolt

Description	7.8mm Cams	9.0mm Cams
Drive 20mm backset	94205	94205
Drive 22mm backset	94225	94225
290-420 EX1 extension	93815	93815
420-760 EX2 extension	93825	93925
760-1060 EX5 extension	93855	93955
1060-1360 EX6 extension	93865	93965

Special long extensions (No. 7 & 8) are available for offset gearbox applications. Call Nico Sales Office for details.

### Mark Two Shootbolt

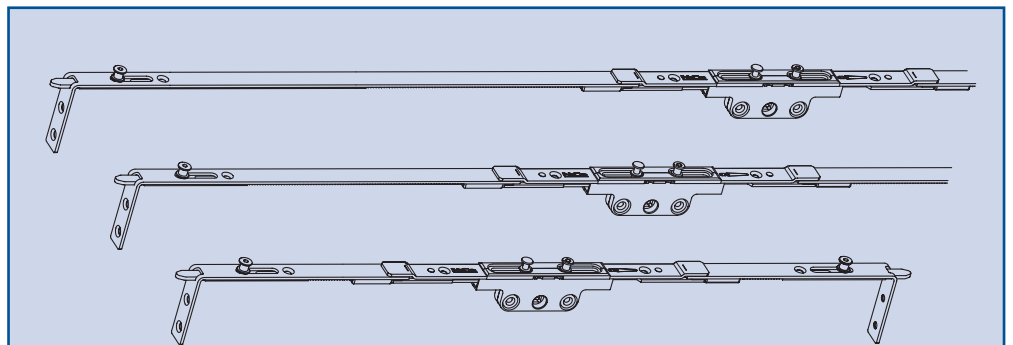

#### Mark Two Shootbolt

Description	7.8mm Cams	9.0mm Cams
Drive 22mm backset	93805	93905
330-460 EX1 extension	93815	93815
460-800 EX2 extension	93825	93925
800-1100 EX3 extension	93835	93935
1100-1400 EX4 extension	93845	93945

Special long extensions (No. 7 & 8) are available for offset gearbox applications. Call Nico Sales Office for details.

Secured by Design



Official Police Security Initiative

A SBD Member Company



ISO 9001 Cert No: Q 09355

Nico Manufacturing Ltd

Oxford Road, Clacton-on-Sea  
Essex CO15 3TJ, England.

Tel: 01255 422333

Fax: 01255 432909

E-mail: sales@nico.co.uk

Web: www.nico.co.uk

For sales, call 01255 422333 or email sales@nico.co.uk