

NiCo

www.nico.co.uk



security plus friction hinge

easy fit for maximum security

The Nico Security Plus Hinge features a unique patented design for added strength, with a hooked nose bar and free moving nose cap that are designed to lock together when forced entry is attempted.



The nosecap is designed to resist forced entry.

As a result, the Security Plus Friction Hinge is the fast, easy way to provide added security to PVCu, timber or aluminium windows. For even more security, it can be used with Nico X-tra Bolts.

The Security Plus Hinge has been endurance tested to 30,000 cycles in the Nico Test Centre.



Nico Security Plus Hinge in 17mm high stack version.

Secured by Design



Police Preferred Specification

MADE IN BRITAIN

**SBD Approved Product
with Nico X-tra Bolt**

Fast simple installation

Patented design

**Security and endurance
tested**

**Robust construction and
smooth action**

**Meets PAS024:2016
as a critical component**

**ISO 9001:2015
Manufacturer**

For sales, call 01255 422333 or email sales@nico.co.uk

Fitting Instructions

Nico Friction Hinges are designed to make fitting as simple as possible. There are slotted fixing holes in the base channel and sash bar, with final fixing holes in each component. This configuration allows a maximum of sash to frame adjustment during fitting and window installation.

Friction Hinge mounting faces must be flat, parallel and provide the correct cavity clearance, 13mm or 17mm (-0mm+1mm).

Friction Hinges should be fitted with the end-cap abutting the corner of the window frame. The centre line of both vent and frame arm should be coincidental and parallel.

Size and weight parameters are to be strictly observed – please refer to Nico for other applications.

After installation, the friction screw should be adjusted to obtain the desired resistance.

All window hardware requires regular inspection, cleaning and maintenance for optimum performance.

security plus friction hinge

Technical Data

Designed after extensive research and development, the Nico Security Plus Hinge combines fabricator-friendly design with strength and value.

With no need for jigs or additional, time-consuming operations, the Hinge is as easy and fast to fit as a standard Friction Hinge. The nose cap requires no fixing and there are no exposed holes after fitting.

The Security Plus Hinge is available in a range of sizes, from 200mm to 600mm for top hung windows, 300mm and 400mm for side hung windows.

13mm and 17mm stack heights suit most profiles. There are slotted fixing holes in the base channel and sash bar with final fixing holes in each component to provide maximum sash/frame adjustment.

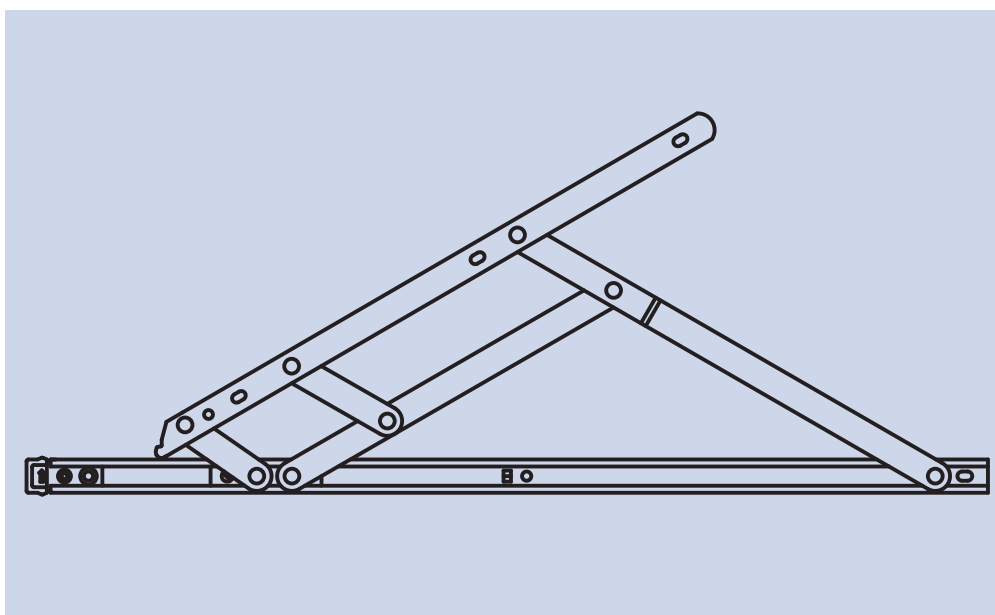

Security Plus Hinge

Size	200mm (8")	250mm (10")	300mm (12")	300mm (12")
Vent Type	Top Hung	Top Hung	Top Hung	Side Hung
Max Vent Width	n/a	n/a	n/a	600mm
Max Vent Height	350mm	450mm	550mm	n/a
Max Vent Weight	12kg	16kg	22kg	22kg
Opening Angle	60°	65°	60°	60°
Bulk Packed	20	40	40	40
Order No.13mm LH	8010L	8020L	8035L	8035L
Order No.13mm RH	8010R	8020R	8035R	8035R
Order No.17mm LH	8110L	8120L	8135L	8135L
Order No.17mm RH	8110R	8120R	8135R	8135R
Size	400mm (16")	400mm (16")	500mm (20")	600mm (24")
Vent Type	Top Hung	Side Hung	Top Hung	Top Hung
Max Vent Width	n/a	700mm	n/a	n/a
Max Vent Height	750mm	n/a	1000mm	1300mm
Max Vent Weight	26kg	26kg	28kg	40kg
Opening Angle	60°	60°	52°	38°
Bulk Packed	40	40	20	20
Order No.13mm LH	8045L	8040L	8050L	8060L
Order No.13mm RH	8045R	8040R	8050R	8060R
Order No.17mm LH	8145L	8140L	8150L	8160L
Order No.17mm RH	8145R	8140R	8150R	8160R



ISO 9001 Cert No: Q 09355

Nico Manufacturing Ltd

Oxford Road, Clacton-on-Sea
Essex CO15 3TJ, England.

Tel: 01255 422333

Fax: 01255 432909

E-mail: sales@nico.co.uk

Web: www.nico.co.uk

For sales, call 01255 422333 or email sales@nico.co.uk