

NiCo

www.nico.co.uk

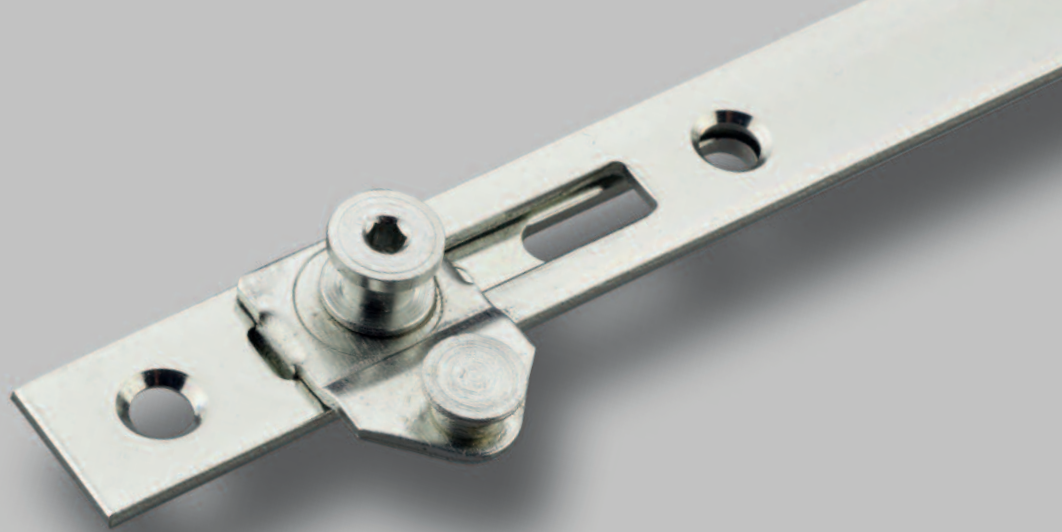

security espagnolette

secure solution for flush fit windows

The Nico Security Espagnolette and striker is a high performance security locking system that is exceptionally strong and easy to fit.

The Security Espagnolette provides an effective, secure locking system and a smooth closing action. The innovative design will easily meet the requirements of PAS024:2016 as a critical component, and is suitable for many flush fitting window profiles.

Like the rest of the UK manufactured Nico Locking System Range, the quality build and product-specific steel keeps combine to ensure a long reliable life.

What is more, the attractive Supercoat 500 silver finish provides excellent corrosion resistance.

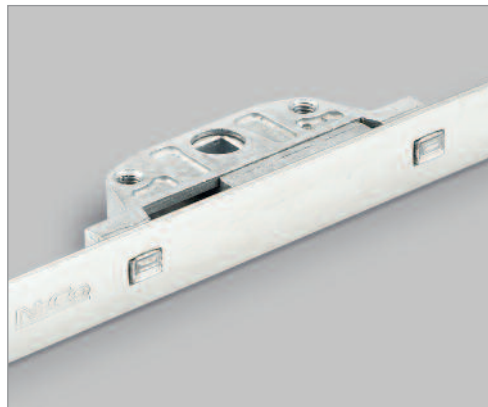

ABOVE: Diecast gear box ensures long lasting performance.

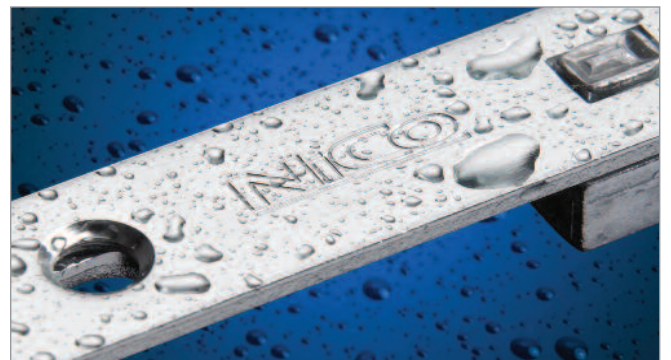

RIGHT: Nico Supercoat 500 is a special corrosion resistant coating. Test Results indicate that finished products have achieved grade 5 (exceptionally high resistance to corrosion) as defined in BS EN 1670:2007, making them suitable for coastal or industrial environments.

Secured by Design



Police Preferred Specification

MADE IN BRITAIN

SBD Approved Product

Proven double cam design

Night vent facility

Simple to install

Meets PAS024:2016 as a critical component

Supercoat 500 silver corrosion resistant finish

ISO 9001:2015 Manufacturer

For sales, call 01255 422333 or email sales@nico.co.uk

Fitting Instructions

Mark the desired centre for the handle mechanism, machine a slot in the centre of the Eurogroove 12mm (10.5mm min) x 90mm long.

Drill a 12mm hole on the above centre line, 20mm or 22mm back from the front face of the Espagnolette. Also drill two 10mm holes 21.5mm either side of the centre hole. (Note: these hole sizes may vary)

Secure the Espagnolette in the sash ensuring that the handle driving mechanism is aligned with the handle mounting holes.

Set the Espagnolette in an unlocked position and locate the keeps in the frame to clear the locking cams.

Check that the locking cams are fully engaged with the keeps when the Espagnolette is locked.

Secure keeps to frame and adjust eccentric cams if necessary.

security espagnolette

Technical Data

The Nico Security Espagnolette is easy to fit and has adjustable seal compression. For fabricator convenience, it uses the same preparation as Nico Standard and High Security Espagnolettes and Shootbolts.

It is available in a traditional 22mm backset, with a 7mm square spindle drive and operating handle fixing holes at 43mm centres.

The eccentrically adjustable 8mm or 9mm cams can be adjusted +/- 1mm for weatherseal compression.

The Security Espagnolette has been endurance tested over a 30,000 duty cycle in the Nico Test Centre.

A product specific range of profile keeps is also available.

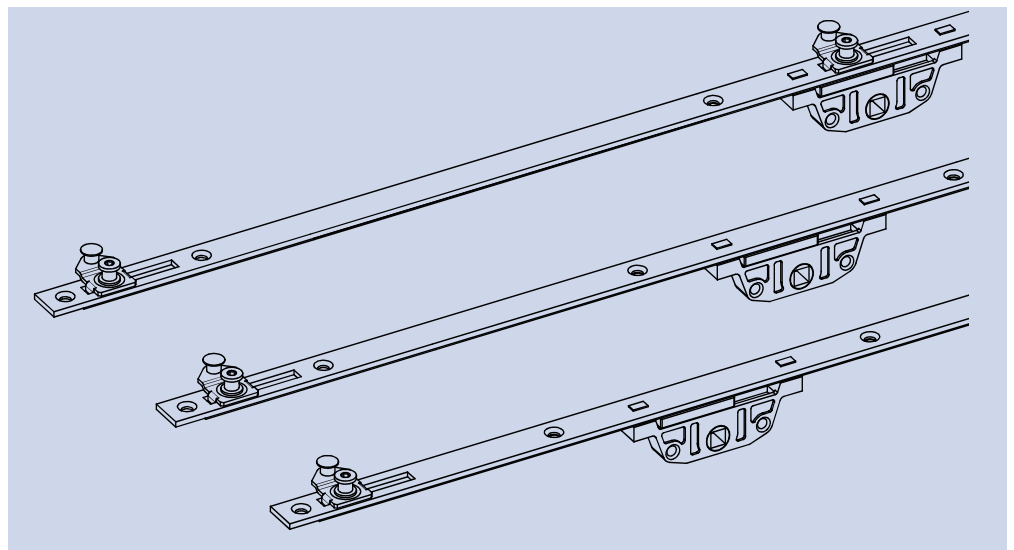

Security Espagnolette

22mm Backset Espagnolettes

Description	Product Order No.	Number of Keeps required	Box Quantity
6.0 Cams			
170mm Security Espagnolette Bolt	92172S5	2	20
350mm Security Espagnolette Bolt	92352S5	2	20
550mm Security Espagnolette Bolt	92552S5	2	20
750mm Security Espagnolette Bolt	92752S5	2	20
950mm Security Espagnolette Bolt	92952S5	3	20
1150mm Security Espagnolette Bolt	921152S5	3	20

22mm Backset Espagnolettes

Description	Product Order No.	Number of Keeps required	Box Quantity
9.0 Cams			
170mm Security Espagnolette Bolt	92171S5	2	20
350mm Security Espagnolette Bolt	92351S5	2	20
550mm Security Espagnolette Bolt	92551S5	2	20
750mm Security Espagnolette Bolt	92751S5	2	20
950mm Security Espagnolette Bolt	92951S5	3	20
1150mm Security Espagnolette Bolt	921151S5	3	20

Keeps

Description	Product Order No.	Box Quantity
Veka Flush Fit Mushroom Keep	9206KS5	200
8.5mm Security Mushroom Keep	9210KS5	200
9.5mm Security Mushroom Keep	9208KS5	200
11mm Security Mushroom Keep	9209KS5	200



ISO 9001 Cert No: Q 09355

Nico Manufacturing Ltd

Oxford Road, Clacton-on-Sea
Essex CO15 3TJ, England.

Tel: 01255 422333

Fax: 01255 432909

E-mail: sales@nico.co.uk

Web: www.nico.co.uk

For sales, call 01255 422333 or email sales@nico.co.uk