



Test Report No: WTH2414#1-1

Date: 15/08/2024

Testing of: Single side hung flush casement window

Tested to: PAS 24 : 2022

Prepared for: Nico Manufacturing Ltd

This report shall not be reproduced except in full, (and then only as permitted by copyright laws), without written approval from The Window Test House.  
Signatures used in this report are held on file.

|                             |  |
|-----------------------------|--|
| Test Report No. WTH2414#1-1 | Page 2 of 14                           |
| Testing of                  | Single side hung flush casement window |
| Testing to                  | PAS 24 : 2022                          |



**CONTENTS**

|   | Page No. |
|---|----------|
| Authorisation                                       | 3        |
| Test requested by                                   | 4        |
| Details of test                                     | 5        |
| Details of samples                                  | 6        |
| Conclusion of tests                                 | 7        |
| Test window drawing & loads                         | 8        |
| Manipulation & Infill removal test results          | 9        |
| Manual check & additional mech loading test results | 10       |
| Mechanical load test results                        | 11 to 12 |
| Picture of test window                              | 13       |
| Revisions   | 14       |



|                             |  |
|-----------------------------|--|
| Test Report No. WTH2414#1-1 | Page 4 of 14                           |
| Testing of                  | Single side hung flush casement window |
| Testing to                  | PAS 24 : 2022                          |



**TEST REQUESTED BY**

**Origin of test request**

|                  |  |
|------------------|--|
| Company Name     | Nico Manufacturing Ltd                             |
| Company Address  | Oxford Road<br>Clacton on Sea<br>Essex<br>CO15 3TJ |
| Contact          | Ian Harrison                                       |
| Contact position | Sales and Marketing Director                       |

**Quotation Details**

|               |            |
|---------------|------------|
| Quotation No. | WTH2414    |
| Dated:        | 11/07/2024 |

|                             |  |
|-----------------------------|--|
| Test Report No. WTH2414#1-1 | Page 5 of 14                           |
| Testing of                  | Single side hung flush casement window |
| Testing to                  | PAS 24 : 2022                          |



### DETAILS OF TEST

|                          |                                  |
|--------------------------|----------------------------------|
| Description              | Single side hung                 |
| Model / type             | Projecting flush casement window |
| Make / Brand             | Veka Omnia                       |
| Any special requirements |                                  |

|                          |   |
|--------------------------|---|
| Test Specification       | PAS24:2022 Enhanced security performance requirements for doorsets and windows in the UK  |
| Date sample received     | 09/07/2024  |
| Date testing started     | 15/08/2024  |
| Date testing finished    | 15/08/2024  |
| Job No.                  | WTH2414   |
| Any special requirements | Deviation from standard method - Due to the height of the test sample and the limitations of the test rig, the sample was mounted with the bottom of the window 610mm from floor level rather than the 800mm stated in the test standard. |

**C.4.3 Manipulation test.** - Using a variety of tools as detailed in Annex A of PAS24:2022 attempts are made to gain entry by such methods as removal of trim, insertion of tools to slide latches or bolts, undoing threaded fasteners and blows by hand to dislodge locking devices. Test a) takes place prior to infill removal test and test b) after the mechanical loading test.

Prior to infill medium removal test, duration 15 minutes with no single technique being used for more than 3 minutes. If fixings are exposed during mechanical loading test or additional mechanical loading test, duration 3 minutes with the primary intention of releasing threaded fasteners.

**C.4.4.2 Infill medium removal test, Manual.** - Using a variety of tools as detailed in Annex A of PAS24:2022 attempts are made to remove gaskets, beads, security devices and then infill medium.

Test duration is 3 minutes.

**C.4.4.3 Infill medium removal test, Mechanical.** - A load of 2000N is applied to each corner of the infill medium via a 150mm x 150mm wooden block and each load is held for 10 seconds. If failure is exhibited at the corners loading is continued along each section in an attempt to deglaze the window.

**C.4.5 Mechanical loading test.** - Loading consists of the application of a 1000N parallel to plane load which is held until a 3000N perpendicular to plane load has been applied and removed. Loads are applied to each corner and at each locking and hinge point of each opening sash. Loading cases (table C.1) and sequence of loading (figure C.14) are shown in PAS 24:2022.

**C.4.6 Manual check test.** - Using the tools specified in PAS 24:2022 B.4.6.2 attempts are made to gain entry by levering at any location and in any direction such that the combined location and direction of the force applied does not replicated the standard mechanical loading cases.

If entry is gained the new location and the direction of applied loads shall be noted and an additional mechanical loading test shall be performed.

Test duration 15 minutes with no single technique being used for more than 3 minutes

**C.4.7 Additional mechanical loading test.** - Carry out load test in accordance with C.4.5 using the loading configuration defined in C.4.6.

The samples were mounted in timber sub frames (nominal 100mm x 50mm in section).

The samples were mounted in the test rig without any twists or bends that might influence the test result.



**DETAILS OF SAMPLE**

|                        |   |
|------------------------|---|
| Sample details         | Single side hung flush casement window  |
| Fabricator             | Veka PLC  |
| Material:              | PVCU, Mechanically jointed<br>Veka part numbers;<br>Frame - 101.364 55mm outerframe<br>Sash - 103.420 76mm sash<br>Reinforcing - 113428 steel in sash only<br>Jointing - 109862 Pro-join sash moulding & 109865 flush adjustable block                                      |
| Finish                 | Green woodgrain   |
| Lock & keeps           | Lock - Nico MK2 with Triple Lock Ext 7, part no 93905 and 93975-TL/R<br>Keeps - Nico Veka Omnia triple lock centre and corner keeps - part no 9329-C and 9329-L/R   |
| Hinges & protectors    | Hinges - Nico 17mm stack Atlas Easy Clean First, part no 8579L/R<br>Hinge protectors - Nico Xtra bolt, part no 8100   |
| Handle                 | White cranked   |
| Fixings                | Lock - 4.3 x 25mm c'sk head pierce point<br>Keeps - 4.3 x 25mm c'sk head pierce point<br>Hinges - 4.3 x 25mm pan head pierce point to sash and frame<br>Hinge protectors - 4.3 x 25mm pan head pierce point<br>Weather interlock wedges - 4.3 x 25mm c'sk head pierce point |
| Weather sealing        | Co extruded gaskets<br>Pull in wedge (Frame) - 140117.100000<br>Pull in wedge (Sash) - 140117.200000  |
| Glass<br>(or infill)   | 4-20-4 Toughened double glazed unit   |
| Glazing system         | Internally bead glazed with co extruded gaskets<br>Bead - 107.154 bevelled  |
| Sample dimensions      | 1600mm (h) x 850mm (w)  |
| Additional information |   |

|   |              |
|---|--------------|
| Test Report No. WTH2414#1-1                       | Page 7 of 14 |
| Testing of Single side hung flush casement window |              |
| Testing to PAS 24 : 2022                          |              |



**CONCLUSIONS OF TEST**

| Clause No. | Test Description   | Test result     |
|------------|--|-----------------|
| C.4.3      | Manipulation test prior to infill removal test   | Pass            |
| C.4.3      | Manipulation test if fixings are exposed after mechanical loading test or additional mechanical loading test | Pass            |
| C.4.4.2    | Infill removal test - manual   | Pass            |
| C.4.4.3    | Infill removal test - mechanical   | Pass            |
| C.4.5      | Mechanical loading test  | Pass            |
| C.4.6      | Manual check test  | No entry gained |
| C.4.7      | Additional mechanical loading test   | N/A             |

|   |   |
|---|---|
| <b>Classification (As per clause 4.4)</b> | W |
|---|---|

The results contained in this report apply only to the samples tested as received and to the specific tests carried out within this report.

**Test specimen details**

Details of the samples construction and hardware components is based on information supplied by the test client, while these details have been checked and verified where possible WTH accepts no responsibility for the accuracy of details supplied.

Note : The test specimens were kept in the test laboratory for a minimum of 12 hours at environmental conditions of between 15°C to 30°C, and 25% to 75% RH before each test was undertaken as specified in PAS 24:2022 Clause C.4.1



**TEST WINDOW DRAWING**

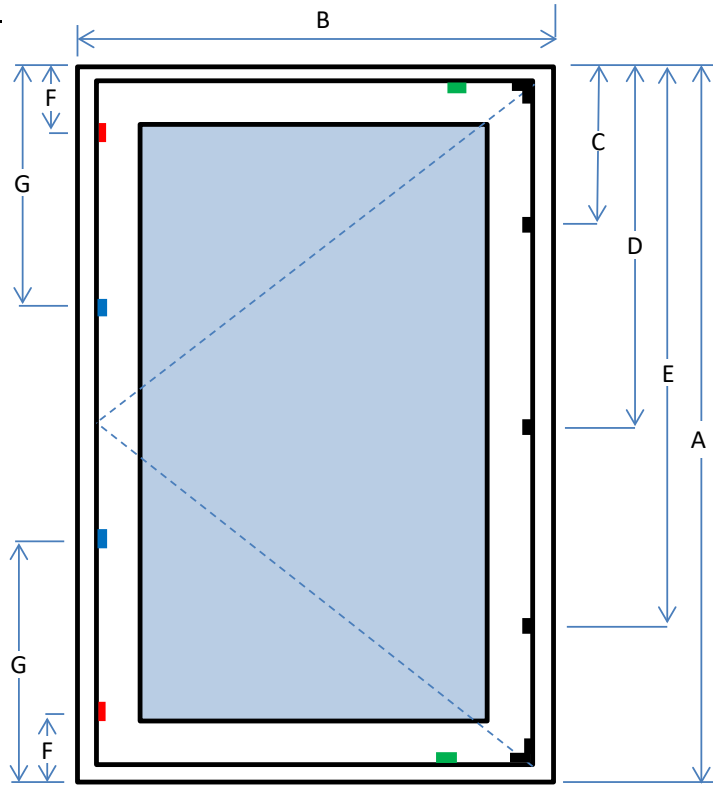

- Hinge protectors
- Riser block
- Pull in wedge
- Lock point

- A = 1600 mm
- B = 850 mm
- C = 455 mm
- D = 800 mm
- E = 1150 mm
- F = 115 mm
- G = 540 mm

|   |              |
|---|--------------|
| Test Report No. WTH2414#1-1                       | Page 9 of 14 |
| Testing of Single side hung flush casement window |              |
| Testing to PAS 24 : 2022                          |              |



#### MANIPULATION TEST

| Sample No | Temperature | Measured Humidity | Adjusted humidity | Date       |
|-----------|-------------|-------------------|-------------------|------------|
| WTH2414B  | 25.5 °C     | 41 %RH            | 39.6 %RH          | 15/08/2024 |

##### Clause 4.3 Manipulation test prior to infill removal test.

Craft knife used to cut away sash profile adjacent to bottom intermediate lock point, paint scraper used with hand blows in attempt to disengage cam from keep and to break keep - No entry gained  
 Craft knife used to cut away sash profile adjacent to bottom lock point, paint scraper used with hand blows in attempt to disengage cam from keep - No entry gained  
 Craft knife used to cut away sash profile adjacent to top intermediate lock point, 3mm flat blade screwdriver used in attempt to breakaway front leg of keep - No entry gained  
 Craft knife used to cut away sash profile adjacent to bottom hinge protector, 3mm flat blade screwdriver used in attempt to remove screws - No entry gained  
 Craft knife used to cut sash profile adjacent to centre lock point, paint scraper used in attempt to disengage cam from keep - No entry gained

#### INFILL MEDIUM REMOVAL TEST

| Sample No | Temperature | Measured Humidity | Adjusted humidity | Date       |
|-----------|-------------|-------------------|-------------------|------------|
| WTH2414B  | 25.4 °C     | 42.5 %RH          | 41.2 %RH          | 15/08/2024 |

##### Clause 4.4.2 Infill manual test

Craft knife used to cut vee notch in sash profile, 6mm chisel used to finish removing cut profile and attempt to get to glazing bead - No entry gained

#### MANUAL CHECK TEST

| Sample No | Temperature | Measured Humidity | Adjusted humidity | Date       |
|-----------|-------------|-------------------|-------------------|------------|
| WTH2414B  | 25.4 °C     | 41.4 %RH          | 40.0 %RH          | 15/08/2024 |

##### Clause 4.6 Manual check test (note tools used and time taken)

2 off Nail bars used to lever between centre and lower intermediate lock points - No entry gained  
 2 off Nail bars used to lever at central point at bottom of sash - No entry gained  
 2 off Nail bars used to lever between bottom and lower intermediate lock points - No entry gained  
 2 off Nail bars used to lever at centre of hinge side of sash - No entry gained

|   |               |
|---|---------------|
| Test Report No. WTH2414#1-1                       | Page 10 of 14 |
| Testing of Single side hung flush casement window |               |
| Testing to PAS 24 : 2022                          |               |



**IINFILL MEDIUM REMOVAL TEST**

| Sample No | Temperature |    | Measured Humidity |     | Adjusted humidity |     | Date       |
|-----------|-------------|----|-------------------|-----|-------------------|-----|------------|
| WTH2414B  | 25.8        | °C | 56.7              | %RH | 56.3              | %RH | 15/08/2024 |

**Clause 4.4.3 Infill mechanical test**

All four corners of glazing loaded in turn to 2000N and held for 10 seconds - No entry gained

**ADDITIONAL MECHANICAL LOADING TEST**

| Sample No | Temperature |    | Measured Humidity |     | Adjusted humidity |     | Date |
|-----------|-------------|----|-------------------|-----|-------------------|-----|------|
|           |             | °C |                   | %RH | -4.0              | %RH |      |

**Clause 4.7 Additional mechanical loading test**

**MANIPULATION TEST**

| Sample No | Temperature |    | Measured Humidity |     | Adjusted humidity |     | Date       |
|-----------|-------------|----|-------------------|-----|-------------------|-----|------------|
| WTH2414B  | 25.5        | °C | 41.3              | %RH | 39.9              | %RH | 15/08/2024 |

**Clause 4.3 Manipulation test if fixings exposed after mechanical loading test or additional mechanical loading test.**

3mm flat blade screwdriver use to loosen one screw securing hinge protector to sash - No entry gained



**MECHANICAL LOAD TEST**

**Clause 4.5 Mechanical Load test**

| Sample No  | Temperature                    | Measured Humidity                   | Adjusted humidity         | Date       |
|--|--------------------------------|-------------------------------------|---------------------------|------------|
| WTH2414B   | 25.8 °C                        | 55 %RH                              | 54.5 %RH                  | 15/08/2024 |
| Load location  | Parallel to plain load (1000N) | Perpendicular to plain load (3000N) | Observations / Assessment |            |
| 1 Top hinge corner, hinge and hinge protector<br>Vertically down | Load applied                   | Load applied                        | No entry gained           |            |
|  | 1001N                          | 2997N                               |                           |            |
|  | Applied for (s)                | Applied for (s)                     |                           |            |
|  | 32                             | 10                                  |                           |            |
| 1 Top hinge corner, hinge and hinge protector<br>Horizontal      | Load applied                   | Load applied                        | No entry gained           |            |
|  | 998N                           | 2999N                               |                           |            |
|  | Applied for (s)                | Applied for (s)                     |                           |            |
|  | 34                             | 10                                  |                           |            |
| 2 Top opening corner & top lock point<br>Vertically down         | Load applied                   | Load applied                        | No entry gained           |            |
|  | 997N                           | 2999N                               |                           |            |
|  | Applied for (s)                | Applied for (s)                     |                           |            |
|  | 31                             | 10                                  |                           |            |
| 2 Top opening corner & top lock point<br>Horizontal              | Load applied                   | Load applied                        | No entry gained           |            |
|  | 999N                           | 3001N                               |                           |            |
|  | Applied for (s)                | Applied for (s)                     |                           |            |
|  | 32                             | 10                                  |                           |            |
| 3 Top intermediate lock point<br>Vertically down                 | Load applied                   | Load applied                        | No entry gained           |            |
|  | 1003N                          | 2998N                               |                           |            |
|  | Applied for (s)                | Applied for (s)                     |                           |            |
|  | 34                             | 10                                  |                           |            |
| 3 Top intermediate lock point<br>Horizontal                      | Load applied                   | Load applied                        | No entry gained           |            |
|  | 1000N                          | 3000N                               |                           |            |
|  | Applied for (s)                | Applied for (s)                     |                           |            |
|  | 31                             | 10                                  |                           |            |
| 4 Centre lock point<br>Vertically down                           | Load applied                   | Load applied                        | No entry gained           |            |
|  | 1001N                          | 3015N                               |                           |            |
|  | Applied for (s)                | Applied for (s)                     |                           |            |
|  | 30                             | 10                                  |                           |            |
| 4 Centre lock point<br>Vertically up                             | Load applied                   | Load applied                        | No entry gained           |            |
|  | 999N                           | 3013N                               |                           |            |
|  | Applied for (s)                | Applied for (s)                     |                           |            |
|  | 34                             | 10                                  |                           |            |
| 4 Centre lock point<br>Horizontal                                | Load applied                   | Load applied                        | No entry gained           |            |
|  | 997N                           | 3001N                               |                           |            |
|  | Applied for (s)                | Applied for (s)                     |                           |            |
|  | 37                             | 10                                  |                           |            |
| 5 Bottom intermediate lock point<br>Vertically up                | Load applied                   | Load applied                        | No entry gained           |            |
|  | 999N                           | 3006N                               |                           |            |
|  | Applied for (s)                | Applied for (s)                     |                           |            |
|  | 31                             | 10                                  |                           |            |
| 5 Bottom intermediate lock point<br>Horizontal                   | Load applied                   | Load applied                        | No entry gained           |            |
|  | 1000N                          | 3008N                               |                           |            |
|  | Applied for (s)                | Applied for (s)                     |                           |            |
|  | 29                             | 10                                  |                           |            |



**MECHANICAL LOAD TEST CONT.**

**Clause 4.5 Mechanical Load test**

| Sample No  | Temperature                    | Measured Humidity                   | Adjusted humidity         | Date       |
|--|--------------------------------|-------------------------------------|---------------------------|------------|
| WTH2414B   | 25.5 °C                        | 40.2 %RH                            | 38.7 %RH                  | 15/08/2024 |
| Load location  | Parallel to plain load (1000N) | Perpendicular to plain load (3000N) | Observations / Assessment |            |
| 6 Bottom opening corner & bottom lock point<br>Vertically up     | Load applied                   | Load applied                        | No entry gained           |            |
|  | 998N                           | 3012N                               |                           |            |
|  | Applied for (s)                | Applied for (s)                     |                           |            |
| 6 Bottom opening corner & bottom lock point<br>Horizontal        | Load applied                   | Load applied                        | No entry gained           |            |
|  | 1001N                          | 297N                                |                           |            |
|  | Applied for (s)                | Applied for (s)                     |                           |            |
| 7 Bottom hinge corner hinge and hinge protector<br>Vertically up | Load applied                   | Load applied                        | No entry gained           |            |
|  | 1003N                          | 3004N                               |                           |            |
|  | Applied for (s)                | Applied for (s)                     |                           |            |
| 7 Bottom hinge corner hinge and hinge protector<br>Horizontal    | Load applied                   | Load applied                        | No entry gained           |            |
|  | 998N                           | 3010N                               |                           |            |
|  | Applied for (s)                | Applied for (s)                     |                           |            |
|  | Load applied                   | Load applied                        |                           |            |
|  |                                |                                     |                           |            |
|  | Applied for (s)                | Applied for (s)                     |                           |            |
|  | Load applied                   | Load applied                        |                           |            |
|  |                                |                                     |                           |            |
|  | Applied for (s)                | Applied for (s)                     |                           |            |
|  | Load applied                   | Load applied                        |                           |            |
|  |                                |                                     |                           |            |
|  | Applied for (s)                | Applied for (s)                     |                           |            |
|  | Load applied                   | Load applied                        |                           |            |
|  |                                |                                     |                           |            |
|  | Applied for (s)                | Applied for (s)                     |                           |            |
|  | Load applied                   | Load applied                        |                           |            |
|  |                                |                                     |                           |            |
|  | Applied for (s)                | Applied for (s)                     |                           |            |

|   |               |
|---|---------------|
| Test Report No. WTH2414#1-1                       | Page 13 of 14 |
| Testing of Single side hung flush casement window |               |
| Testing to PAS 24 : 2022                          |               |



**PICTURE OF TEST WINDOW**



**END OF REPORT**

|                             |  |
|-----------------------------|--|
| Test Report No. WTH2414#1-1 | Page 14 of 14                          |
| Testing of                  | Single side hung flush casement window |
| Testing to                  | PAS 24 : 2022                          |

**Revision History**

|                      |   |                |            |
|----------------------|---|----------------|------------|
| Issue No:            | Rev 1   | Re-Issue date: | 01/11/2024 |
| Revised By:          | D.Kury  | Approved by:   | B.Powell   |
| Reason for revision: | Deviation from standard method detailed on page 5<br>This had been omitted from original report |                |            |

|                      |  |                |  |
|----------------------|--|----------------|--|
| Issue No:            |  | Re-Issue date: |  |
| Revised By:          |  | Approved by:   |  |
| Reason for revision: |  |                |  |